



PRODUCT INFORMATION BULLETIN

Date: September 22, 2015
Number: 8889
Division: Genie®
Product Family: Commercial Operators
Product Series: Genie Commercial GCL-T and GCL-GT Trolley Systems
To: All Genie Professional Line Wholesalers, Dealers and Installers
Re: Heavy and Standard Duty Dual Trolley Improvements

Several changes have been made to the standard-duty (OPAKDT.S) and heavy-duty (OPAKDTHX.S) dual trolley kits.

Bushings on the header bracket assembly have been upgraded to bearings to improve reliability. In addition to the change, spacers have been added on both sides of the header sprocket to retain the key position in the event that the sprocket bolt loosens. The set screw in the sprocket has also been changed to a square head bolt to improve the ability to apply torque when tightening the sprocket to the header shaft. All these changes were in effect as of September 17, 2015.

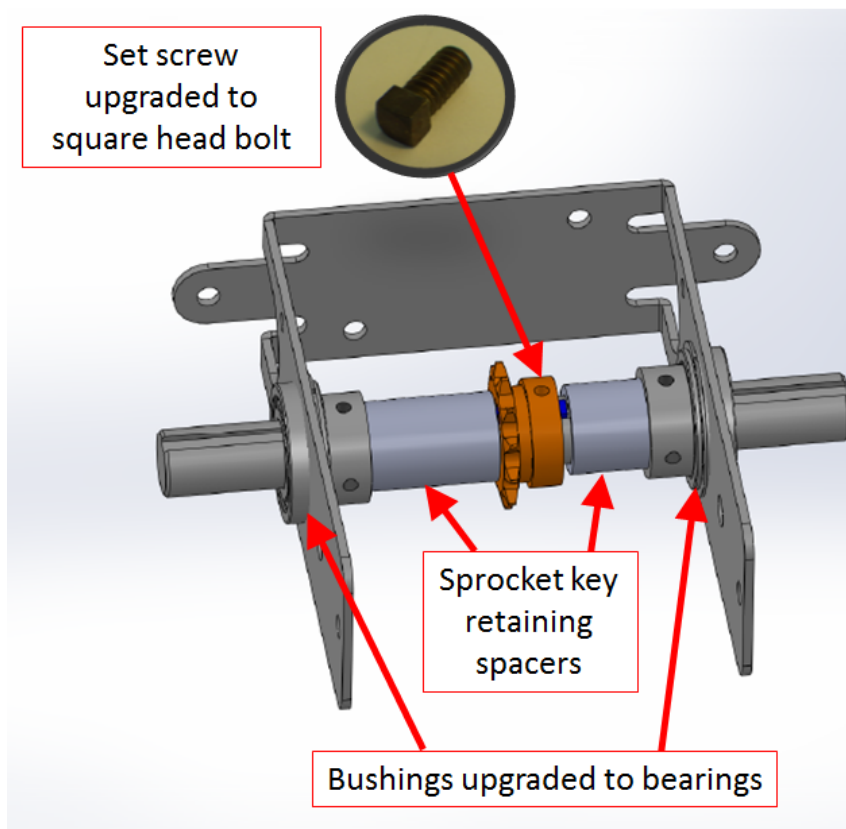

If you have any questions, please contact Technical Support Services at 800-843-4084, option 4.