

NOT FOR RESIDENTIAL USE

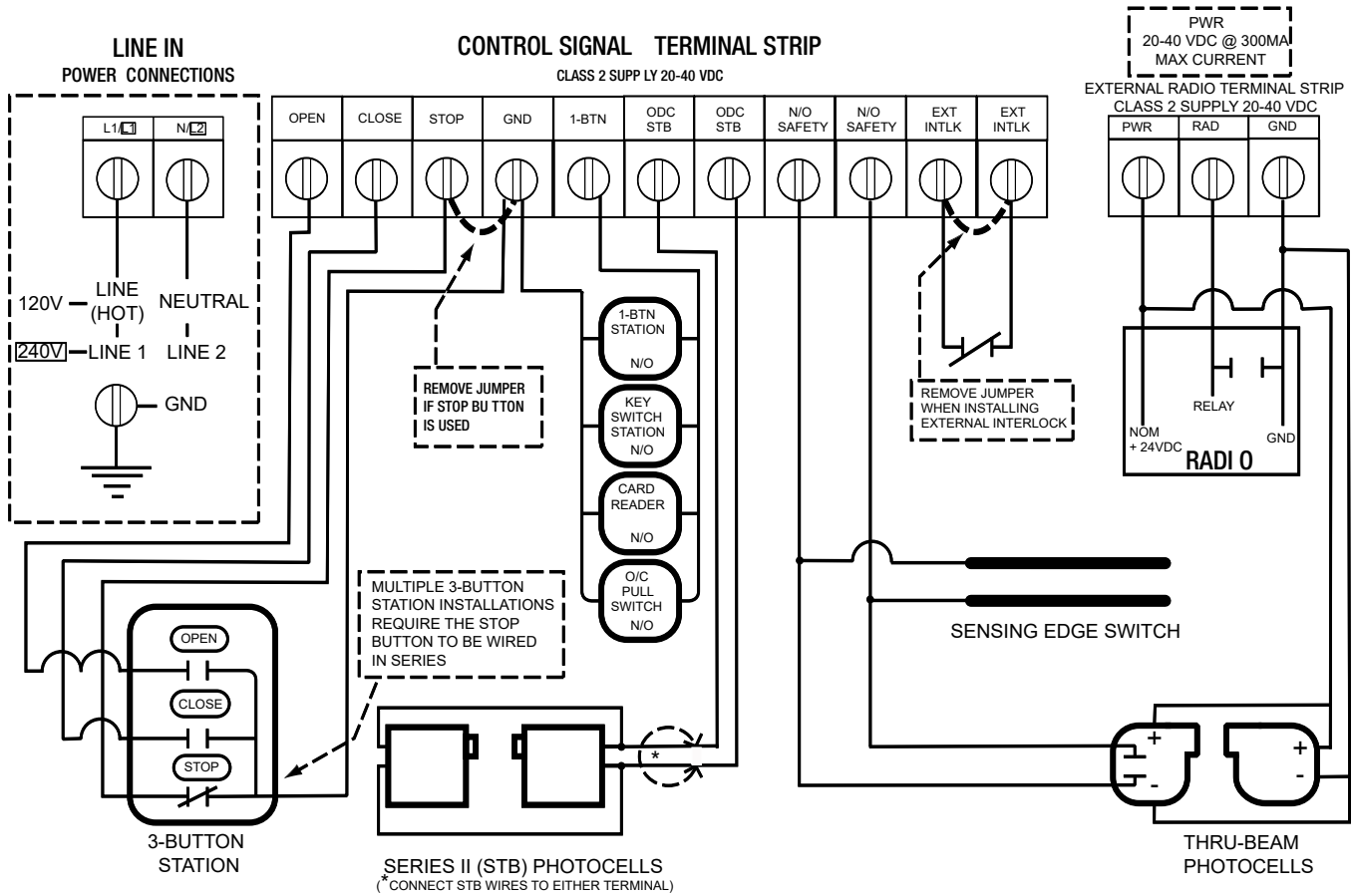

TROUBLESHOOTING LEDS				
HOIST INTERLOCK	EXTERNAL INTERLOCK	24 VOLTS DC	STB ENABLE	INDICATION
			●	STB DISABLED OR STB WIRING SHORT
			Ⓞ	STB ENABLED
Ⓞ	Ⓞ	Ⓞ		NORMAL OPERATING CONDITION
●	Ⓞ	Ⓞ		HOIST INTERLOCK SWITCH OPEN: 1.) HOIST RELEASE NEEDS RESET. 2.) HOIST INTERLOCK CONNECTOR NOT PLUGGED IN. 3.) HOIST INTERLOCK DEFECTIVE.
●	●	Ⓞ		EXTERNAL INTERLOCK OPEN
●	●	●		POWER SUPPLY PROBLEM: 1.) CHECK AC POWER SUPPLY. 2.) CHECK MAIN POWER FUSE. 3.) CHECK SECONDARY FUSE (2A)

GCL-MJ

MEDIUM-DUTY JACKSHAFT OPERATOR

WIRING DIAGRAM

Warning: For continued protection against fire, replace fuses only with the same type and rating.

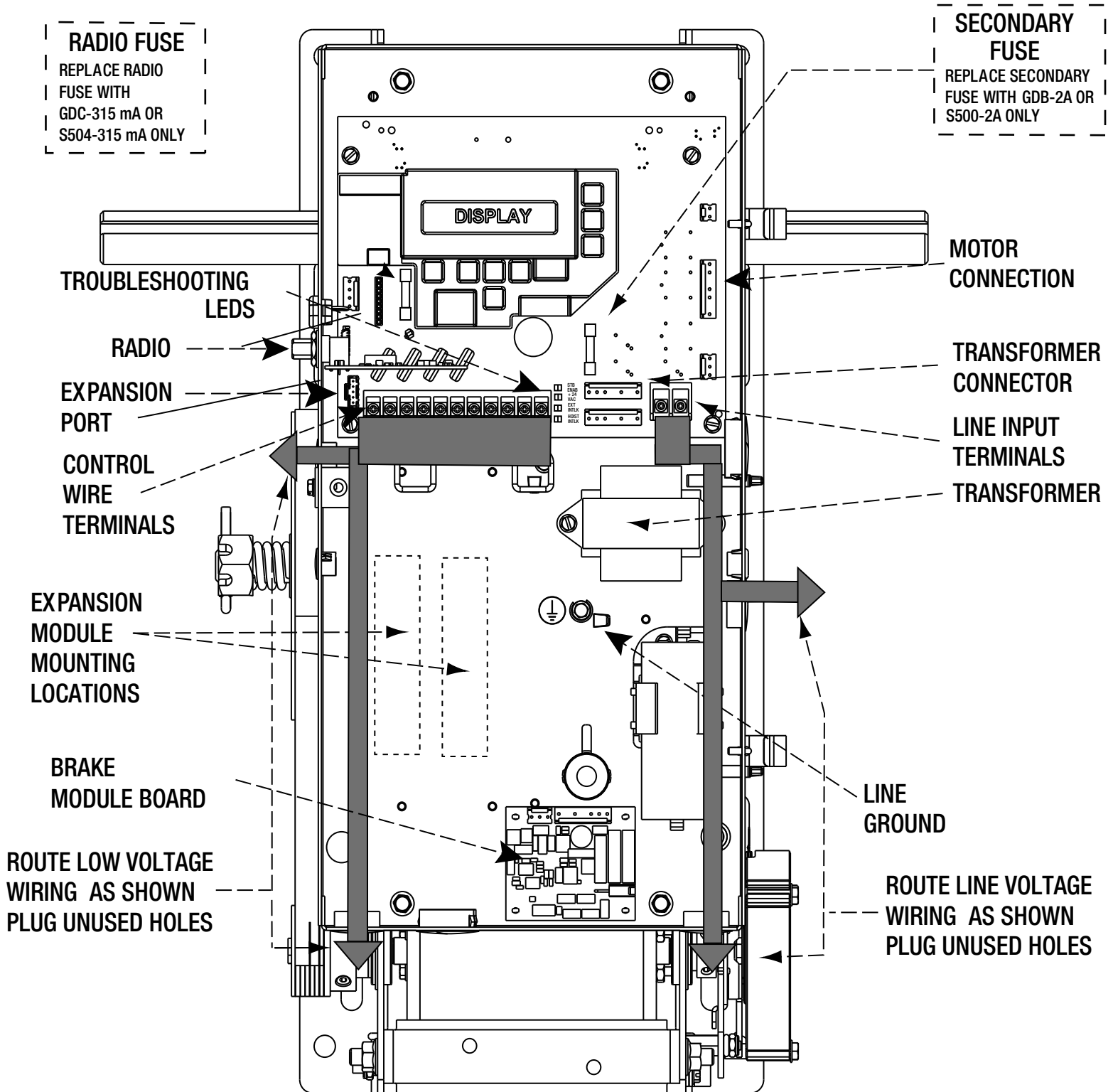

CAUTION: To prevent the motor protector from tripping, do not exceed 15 cycles of opening and closing per hour. For limited-duty only.



www.GenieCompany.com/commercial

©2022 The Genie Company